

10

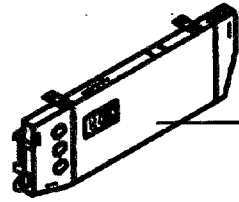

25



110



27

27

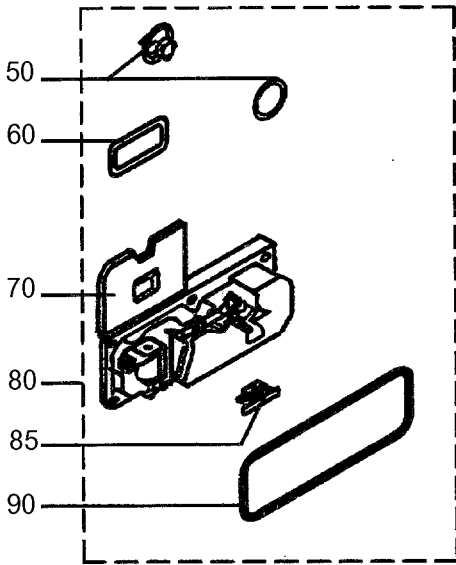

50

60

70

80

85

90

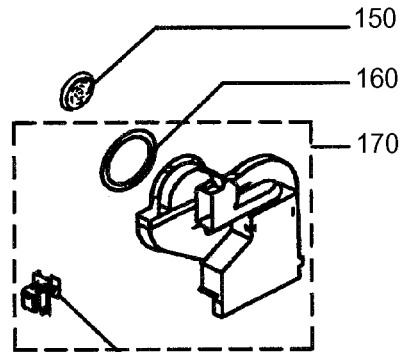

150

160

170

180

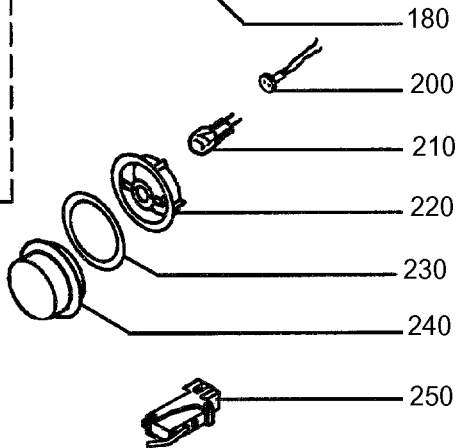

200

210

220

230

240

250

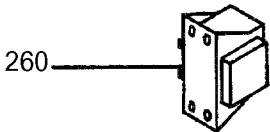

260